

Variable Pitch Pulley Adjustment

RPA400 TO 600

All units (RPA400 - 600) are fitted with a variable pitch pulley so that the full potential of the motor can be utilised. The pulley is set at the factory to approximate the full motor load with the unit at free delivery. When installed and operating against system resistance, (with doors and windows open) adjustment may be made to the pulley in order that all the available power is utilised.

Method of Variable Pulley Adjustment.

1. Ensure installation is complete and that all registers are set to their maximum openings.
2. Operate the unit and allow the motor to warm up (10 - 15 minutes).
3. Measure the current being drawn by the motor on high speed.
4. Compare the rated current shown on the rating plate, to the measured current.
If the current is significantly above or below the rated current, pulley adjustment may be made as follows.
5. Isolate power to unit and remove the " V " belt/s. Loosen the grub screws in the flange of the pulley. Screw pulley flange in to increase the blower speed and amperage, and screw it out to decrease blower speed and amperage.
Re-tighten the grub screws in the flange evenly.
6. Adjust the pulley as shown in figure below.
7. It will be necessary to adjust the belt tension by using the jacking screws after any pulley adjustment has been made.
8. A new drive can be tightened initially 50% more than normal to allow for the drop in tension during run-in.

CAUTION: When turning pulley counter clockwise to reduce blower speed, be sure that pulley is not opened far enough to permit the belt ride on the threaded part of pulley, as this will cause damage to the belt

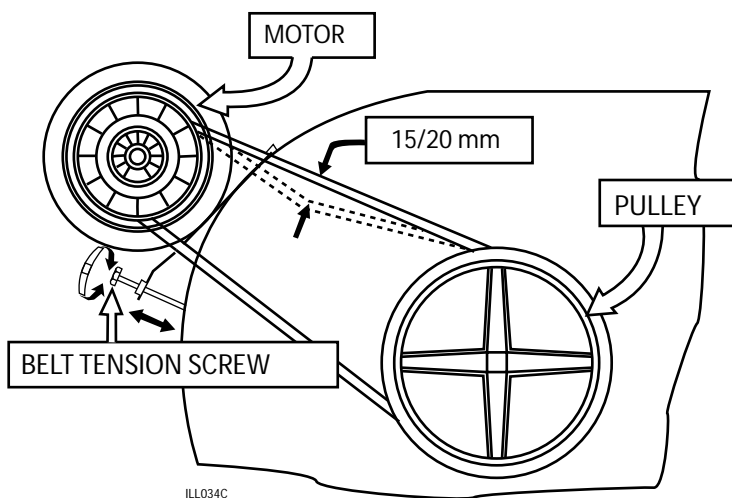

Note.
Too great a belt tension will increase motor load, and shorten belt and bearing life.
Too loose a belt will cause belt slippage and excessive belt and pulley wear.

Pulley Adjustment

Models RPA1000 - RPA1300 are supplied with variable pitch pulleys.

(Models RPA1500 - RPA1800 are supplied with Fixed size pulleys.)

(Models RPB600 - RPB1800 are supplied with Fixed size pulleys.)

Method of Variable Pulley Adjustment.

1. Ensure installation is complete and that all registers are set to their maximum openings.
2. Operate the unit and allow the motor to warm up (10 - 15 minutes).
3. Measure the current drawn by the motor on high speed.
4. Compare the rated current shown on the rating plate, to the measured current.
If the current is significantly above or below the rated current, pulley adjustment may be made as follows.
5. Isolate unit and remove the " V " belt/s. Loosen the grub screws in the flange of the pulley. Screw pulley flange in to increase the blower speed and amperage, and screw it out to decrease blower speed and amperage.
Re-tighten the grub screws in the flange evenly.
6. Adjust the pulley as shown in figure below.
7. It will be necessary to adjust the belt tension by using the screws securing the motor mount after any pulley adjustment has been made.
8. A new drive can be tightened initially 50% more than normal to allow for the drop in tension during run-in.

Belt Tensioning

Models RPA700 to 1800
RPB600 to 1800

CAUTION: When turning pulley counter clockwise to reduce blower speed, be sure that pulley is not opened far enough to permit the belt ride on the threaded part of pulley, as this will cause damage to the belt

Note.

Too great a belt tension will increase motor load, and shorten belt and bearing life.
Too loose a belt will cause belt slippage

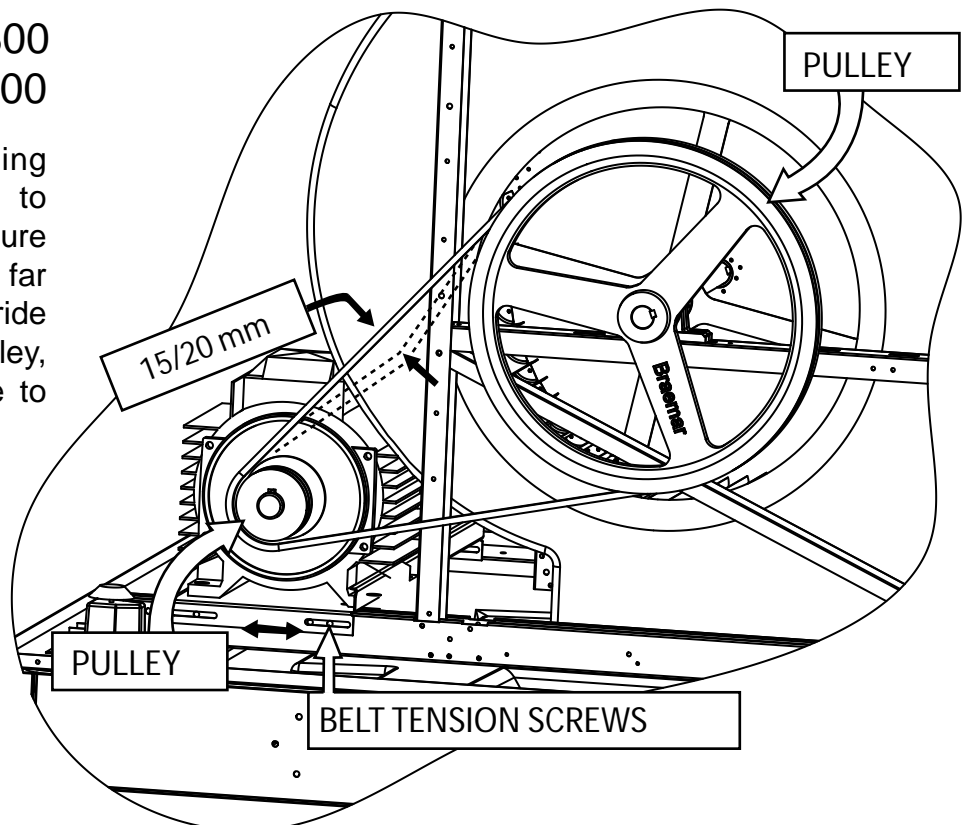

Variable Pitch Pulley Adjustment

RPC Coolers

All RPC units are fitted with a variable pitch pulley so that the full potential of the motor can be utilised. The pulley is set at the factory to approximate the full motor load with the unit at free delivery. When installed and operating against system resistance, (with doors and windows open fully) adjustment may be made to the pulley in order that all the available power is utilised.

PULLEY ADJUSTMENT

Important! Never attempt this adjustment with the Cooler operating. Pulley adjustment is made with the Cooler power switched OFF at the switch inside the cooler

(1)..... Remove the drive belt.

(2).....To adjust the pulley: (Fig 1) remove the securing screw (D) that holds the locking cap (A) in place, then remove the cap. The adjustable half of the pulley is now free to be adjusted by rotating it by hand.

(3).....To increase the blower speed and therefore increase the motor amps, the two halves of the pulley must be closer together, ie. hold the fixed half of the pulley (E) with one hand and turn the adjustable half of the pulley (C) clockwise with the other hand (pulley in).

(4).....To decrease the blower speed and therefore decrease the motor amps, the two halves of the pulley must be further apart, i.e.. hold the fixed half of the pulley (E) with one hand and turn the adjustable half of the pulley (C) anti-clockwise with the other hand (pulley out).

(5).....When an adjustment is made: (Fig 1) replace the locking cap by aligning the nearest screw holes of the adjustable half of the pulley with the holes in the locking ring. Lock the ring into place with the securing screw, take care not to strip the thread by over tightening the screw. Refit the belt, ensure tension is correct (i.e. no slipping and not too tight, as this will affect the motor amps) then check the motor amps.

(6).....Smaller adjustments should be made each time you approach the desired setting. See heading 'Belt Tension' in the installation manual for correct belt setting.

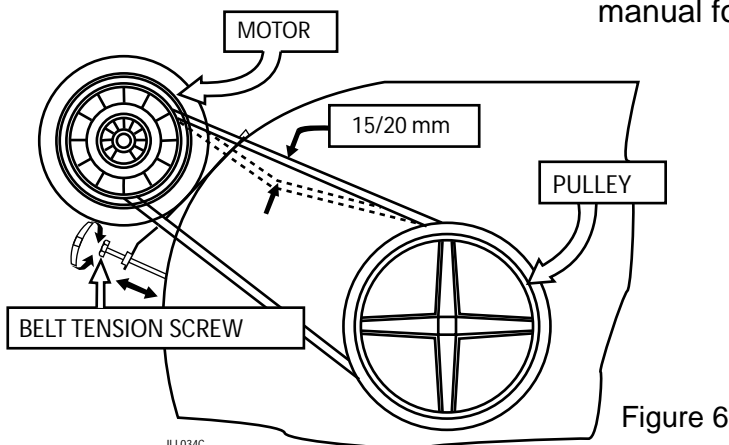
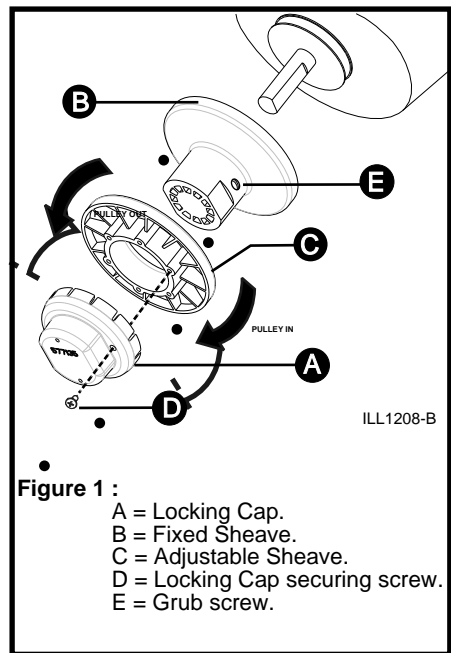

Note.
 Too great a belt tension will increase motor load, and shorten belt and bearing life.
 Too loose a belt will cause belt slippage and excessive belt and pulley wear.

It is the policy of Seeley International to introduce continual product improvement. Accordingly, specifications are subject to change without notice. Please consult with your dealer to confirm the specifications of the model selected.